

OR-10-016

---

# Energy Efficient TES Designs for Commercial DX Systems

**Robert Willis**  
Associate Member ASHRAE

**Brian Parsonnet**

## ABSTRACT

*This paper describes the basis for an energy efficient refrigerant-based thermal energy storage system design for commercial DX systems. A description of a system is given, and design aspects contributing to energy efficiency are identified. Similarly, operating characteristics and strategies contributing to energy efficiency are discussed. Challenges in measuring and predicting energy efficiency are identified, along with a proposed method for collecting certified performance data, and sample test results. Field data is then analyzed to determine if it is consistent with energy savings predictions. The benefits of using such energy efficient thermal energy storage systems are then considered for several climate zones. Results show that refrigerant-based thermal energy storage for commercial DX systems is energy neutral or better given specific design considerations and operating strategy.*

## INTRODUCTION

### Background

Historically, thermal energy storage (TES) has been applied to large chiller-based systems in the form of either chilled water or ice storage. The system analyzed in this manuscript is a packaged refrigerant-based ice-on-coil storage subsystem, designed for use with Standard Direct Expansion (DX) equipment. "Standard DX Equipment" means unitary, direct expansion A/C equipment, including but not limited to, split, mini-split, packaged, and single package vertical unit systems. As such, this design is termed a "Unitary Thermal Storage System," or UTSS. It shares many of the same benefits as the chiller-based systems, but is designed to work with standard DX equipment in both new and retrofit applications, and

in a manner that can improve the combined system's overall efficiency. As with the performance of standard DX equipment, specific climates and application conditions will impact the actual amount of net energy used. Measuring the performance of systems in the field is challenging due to the broad range of operating conditions, indoor and outdoor environmental conditions, as well as the range of uncontrollable variables present in the field, such as building design, equipment maintenance, and allowable variations in manufactured OEM equipment itself. For this reason, performance ratings of standard DX systems are lab based, and tested over a well-defined range of controlled operating conditions. The lab data can then be used to evaluate the system's operation over a broad range of conditions, both static and dynamic. This in turn can be used to predict performance and efficiency in real-world applications. As a final step, actual field data can then be analyzed to see if it is consistent with predictions, and to provide indications for further investigation.

### Defining "Energy Neutral or Better"

What is meant by "energy neutral or better?" Storage technologies cannot be 100% efficient. However, with the addition of a UTSS system, a DX system's efficiency can be improved. The improvements offset the UTSS storage losses, for a net improvement in overall efficiency of the hybrid UTSS/DX system. This is what is meant by energy neutrality. In modeling the impact of UTSS, one must compare the same DX system with and without storage. This comparison should be conducted with a year-long (8760 h) analysis in order to assess the full impact of charge and discharge cycles for the UTSS system. Using typical meteorological year (TMY) data, results show that the annual energy consumption of standard

---

**Robert Willis** is a senior development engineer and **Brian Parsonnet** is CTO at Ice Energy, Inc., Windsor, CO.

commercial DX systems is unchanged or slightly improved with the application of refrigerant-based UTSS, within reasonable specified application guidelines and operating strategy. While use of an actual year's data or data from an extreme year may be useful to demonstrate the range of behavior, TMY data is most appropriate for determining typical energy efficiency.

## SYSTEM DESCRIPTION

The TES system discussed in this paper is a UTSS which uses refrigerant for charging and discharging. The two main components of the UTSS system are the storage section and the charging module, which houses the refrigeration equipment for building ice. These components are connected by a refrigerant management system that contains key features responsible for efficient operation. Charging module components, including the compressor, expansion device, and condenser fans, are active during the charge cycle. When the UTSS provides cooling, these components are inactive and refrigerant is supplied to the evaporator with a small refrigerant pump.

The UTSS is always used in conjunction with a DX system, to create a “hybrid” cooling solution as shown in Figure 1. The DX system provides the airflow for cooling from either system.

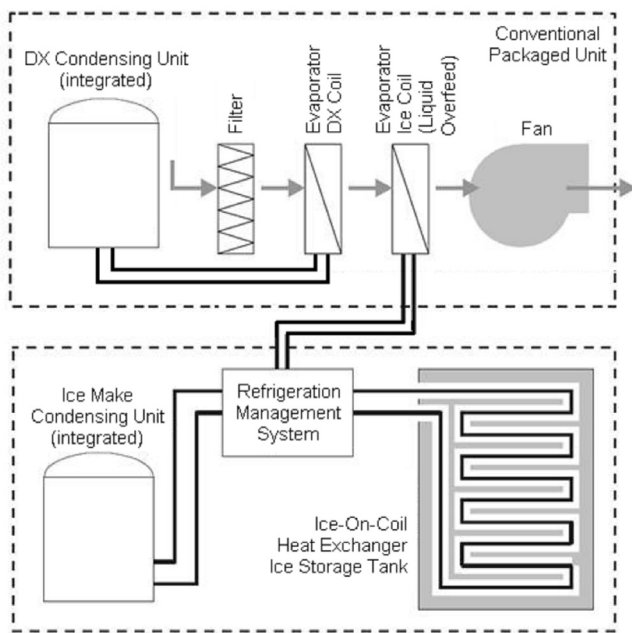

**Figure 1** “Hybrid” cooling solution combining a UTSS and packaged DX system.

## SYSTEM OPERATION

The UTSS has two main modes of operation - charging and cooling. During a scheduled on-peak service time period, commonly Noon – 6:00 P.M., all or part of the building load is served by the UTSS via an evaporator coil inserted in the DX’s air stream. Remaining load, if any, is served by the DX system. (A common configuration, for example, would be for 50% of a 10-ton (35.2 kW) load to be served on-peak by the UTSS, and the other 50% by the DX.) At all other times, such as during the UTSS charge cycle, the DX system provides all the cooling required.

## SYSTEM EFFICIENCY

Factors leading to high efficiency can be categorized as either inherent to the UTSS system itself, or emergent as a result of integration to the DX system. Inherent factors include a refrigerant-based design, use of liquid overfeed for both ice charging and ice cooling, gravity feed, narrow approach temperatures, and control optimizations. Emergent factors include reduced cycling, improved dehumidification, avoidance of rooftop temperatures, reduced coil freeze-up, and cooling capacity that is decoupled from daytime ambient temperature, enabling right-sizing of the DX system.

## Refrigerant-Based Design

The UTSS was designed to operate with refrigerant as the heat transfer fluid for both charge and discharge modes. The particular system discussed here uses R-410A. The use of refrigerant allows a key design strategy contributing to efficient charge cycles. Using gravity alone, the refrigerant is efficiently fed into the storage section of the UTSS, without the use of actively managed valves, pumps, or other control devices. Condensed refrigerant in the refrigerant management system forms a liquid column which increases pressure at the inlet of the storage section and promotes refrigerant flow into the ice storage heat exchanger. The bottom of the heat exchanger is flooded with liquid refrigerant and evenly distributed throughout. As the refrigerant vaporizes, it rises in the heat exchanger, carrying liquid with it. This mixed phase refrigerant is carried to the top of the heat exchanger and back into the refrigerant management system. Here the vapor and liquid are separated. The liquid is immediately sent back to the storage section heat exchanger by gravity while the vapor is condensed by the charging module. This design eliminates the need to pump refrigerant through the heat exchanger, and avoids the associated power draw. In addition, since the refrigerant is gravity fed, refrigerant velocities are low, minimizing losses associated with pressure drop in forced flow situations. The simple refrigerant management system design allows maximum flow and avoids the need for isolation valves and the restriction they would impose on the system. Ultimately, the only active components during the charge cycle are the compressor, expansion device, and condenser fans—no different than the components of a typical condensing unit.

## Liquid Overfeed

As mentioned above, the storage section operates with liquid overfeed. The refrigerant management system (RMS) design effectively separates liquid and vapor, eliminating the need to generate superheat in the storage section heat exchanger. The entire internal surface of the ice storage heat exchanger is wetted with liquid refrigerant, allowing utilization of the full surface area of the heat exchanger for building ice. The result is a heat exchanger that operates with an average approach temperature of 5°F (2.8°C) during the charge cycle. Minimizing the approach temperature reduces the efficiency degradation that results from excessively low compressor suction temperatures.

The RMS use of liquid overfeed also extends to the cooling cycle, during which the building's evaporator coil also operates more efficiently, without the need for a thermostatic expansion valve (TXV), and without any entrained oil. The UTSS cooling cycle capacity is not a function of ambient temperature, and this becomes an important source of efficiency gains for the UTSS/DX system as a whole.

## Charging Conditions

UTSS designed for DX systems benefit from night/day temperature swings. The nameplate energy efficiency of a standard refrigerant-based air conditioning unit degrades as a function of rising temperature. As a general rule, DX cooling systems using R-22 refrigerant experience energy efficiency degradation of about 1.2% per degree (Faramarzi 2004) above 95°F (35°C), equating to a 15% or greater nameplate energy efficiency loss at peak temperatures. R-410A (the refrigerant now universally replacing R-22) exhibits a more aggressive decay, estimated at about 1.6% per degree (Wells et al. 1999, Domanski and Payne 2002). Conversely however, compressor efficiency improves as temperatures fall below 95°F (35°C) (Wells et al. 1999, Domanski and Payne 2002). The UTSS takes full advantage of this swing. It keeps the DX's compressor from running when it's least efficient (during the hottest part of the day), and runs the charging module compressor to make ice when it's most efficient (in the cool of the night). Both of these factors contribute to improved overall hybrid system efficiency.

The UTSS control strategy for the charge mode also includes a delayed start time for charging. This ensures that the system realizes the maximum benefit from cool nighttime temperatures. The system's controller tracks the amount of stored cooling capacity used in the preceding cooling period, and determines the amount of time required to recharge the storage section to full capacity. The delayed charge strategy is intended to allow enough time for a full recharge by morning, commonly targeted at 8:00 A.M. As a result, the charge cycle spends as much time as possible in the vicinity of the coolest part of the night, which is almost universally 6:00 A.M. Another notable charge cycle characteristic is that the charging module compressor starts only once per day, avoiding cycle losses. And since the next day's cooling is delivered

without the use of a compressor, the entire stored capacity is charged and delivered free of cycling losses on either end of the process.

The charge cycle is controlled to recharge the tank every night. This improves efficiency by ensuring maximum DX offset the next day during the scheduled on-peak period. It is important to note that a full recharge does not waste more energy if it goes unused. This is because the parasitic heat losses are a function of the temperature difference between the inside and outside of the storage tank. The full volume of water in the storage tank is not frozen, so the mixed phase temperature inside the tank at equilibrium is 32°F (0°C) for any amount of storage above a few percent. Therefore, losses are not increased by having extra capacity ready to be deployed.

## Cooling Performance

Performance penalties associated with high daytime rooftop temperatures are also eliminated with UTSS operation. According to industry norms, rooftop temperatures exceed ambient conditions by 6 to 8°F (3.3 to 4.4°C), accentuating the degradation of roof mounted DX equipment performance due to temperature (Faramarzi 2004). As an example, on a 115°F (46.1°C) day, the DX condensing unit would be operating at 123°F (50.6°C), degrading efficiency by another 10% (or 12% for R-410A). Ironically, "cool roof" technologies can contribute to this effect by reflecting heat directly into the DX condensing coil surface. However, UTSS systems are unaffected by solar heat gain and elevated rooftop temperatures, since the condensing unit runs during the dark and cool evening hours when rooftop nighttime temperatures decline rapidly back to ambient.

The UTSS utilizes evaporator coils designed for liquid overfeed. The combination of using pumped liquid refrigerant and liquid overfeed improves cooling performance and reduces the need to over-size DX equipment for the sake of meeting design day. This is further enabled by the fact that the cooling capacity does not degrade with increased ambient temperatures, and cycling losses are eliminated by use of a small refrigerant pump. Daytime rooftop temperatures do not impact UTSS cooling performance. In fact, the hotter it gets during the day, the greater the relative site energy efficiency improvement over a standard DX unit.

UTSS systems reduce the impact of over-sizing on energy efficiency. The efficiency degradation for DX systems associated with a rise in temperature is due to both a decrease in cooling capacity, and a simultaneous increase in energy consumption. To compensate for the loss in cooling capacity, the condensing unit must be over-sized to serve the load on the hottest days. Also, system performance degrades with age, commonly estimated to be 1% per year (Proctor and Wilson 1998). As a result of both factors, systems are routinely over-sized 20 to 50% (Proctor et al. 1995). The most obvious consequence of over-sizing is that the compressor is larger than needed on all but the hottest days. So there is a demand (kW) penalty for about 98% of the year's cooling hours (ASHRAE

2005, Chapter 28). Some high Seasonal Energy Efficiency Ratio (SEER) systems address this problem by employing two-stage compressors and variable speed motors that conserve energy over the course of a year, but these systems do not address the over-sizing practice due to degradation with temperature or age. Of course, the UTSS charging module compressor also degrades with age, but the impact is felt off-peak, and therefore its contribution from an efficiency perspective is relatively small. Much more importantly, the UTSS cooling capacity does not degrade with ambient temperature; rather, it is defined by conditions inside the storage tank. The UTSS improves site energy efficiency when combined with a standard DX system because the UTSS doesn't need to be oversized, and the DX system need not be as greatly oversized either, because it is no longer required to run on peak. (The benefit is in the 5 to 20% range and varies as a function of extreme summer peak day temperature.)

UTSS systems also provide dehumidification without negatively impacting the efficiency of the overall system. Humidity is a part of comfort as well as temperature. In fact, the dryer the air, the warmer the comfort set-point (ASHRAE 2005, Chapter 8). During the cooling process, water vapor from the conditioned space condenses on the evaporator coil. After about 10 minutes, condensation starts to collect and drain to the outside. But DX system cycling, exacerbated when oversized, defeats the dehumidification process by turning off the cooling process before 10 minutes, and sometimes after just 2 to 3 minutes. As a result, the air circulation fan, which continues to operate, reintroduces the condensed water back into the conditioned space (Khattar et al. 1987). The UTSS uniquely avoids this problem with the characteristics of pumped liquid overfeed. First, the flooded coil operates to match the actual load on the coil, inherently lengthening its on-time. Second, flooding the coil with refrigerant keeps the evaporator coil cooler for longer, even after cycling off, as residual refrigerant liquid continues to evaporate, further maintaining the dehumidification process. Also, the UTSS evaporator coil temperatures are typically 1 to 2°F (0.6 to 1.1°C) cooler than DX systems, providing enhanced dehumidification through faster condensation as well. This translates into 2 to 4% additional energy savings vs. DX systems.

The use of a small refrigerant pump for providing cooling eliminates the effect of compressor cycling. As a rough approximation, DX systems cycle on/off 30 times per day. Each cycle (power up sequence) carries an energy efficiency penalty during which time the system moves to steady-state conditions. The industry accepted energy efficiency penalty for DX cycling is 18% annually (Proctor et al. 1995). Oversizing accentuates this issue even further, since larger equipment satisfies the load more quickly (Henderson et al. 2000). The UTSS employs a refrigerant pump and avoids the compressor cycling problem completely, both for itself and the DX system: the UTSS starts the charging module compressor exactly once a day, for a minimum loss, and the DX compres-

or does not run (or cycle) during peak hours, reducing the number of DX cycles by 50% or more.

Coil freeze-up accounts for 30% of service calls and is a prevalent problem for DX systems operating in warm, humid conditions. UTSS technology cannot freeze a coil. (It is impossible to make ice from 32°F (0°C) ice.) Since the UTSS system provides the cooling load during the scheduled on-peak time, the extremely poor efficiency due to coil freeze-up in a standard DX system is eliminated for that time period.

## CHALLENGES IN MEASURING AND PREDICTING ENERGY EFFICIENCY

There are many challenges involved with measuring and predicting the energy efficiency of a DX system designed with UTSS. First, measuring efficiency in the field is impractical. Accurate power measurements can be made, but measuring the actual cooling capacity supplied by the system is difficult. Accurate measurement of airflow and air properties is required. The two biggest challenges are measuring humidity and volumetric flow. Humidity sensors are required, since wet bulb measurements are not practical for extended automated testing. Electrical humidity sensors have an approximate accuracy ranging from 1 to 5% (ASHRAE 2005, Chapter 14). Accurate flow rate measurements require a differential pressure measurement system, which measures the pressure drop across an orifice, nozzle, or venturi tube. These systems can result in precision measurements of 0.5 to 2% but are impractical for field measurements. The alternative is to utilize velocity measurements to calculate airflow, but even the best field instruments for measuring velocity, such as a pitot-static tube, have precision of 1 to 5% (ASHRAE 2005, Chapter 14). Even with calibrated instruments, the accuracy of calculated energy efficiency using field measurements is very limited. This task is better served via lab testing.

The most challenging point in predicting energy efficiency is the limitation of forward modeling. Accurate predictions require sophisticated models that consider the differences in operating characteristics between a DX system and a UTSS. Mapping the performance of both systems over a range of indoor and outdoor conditions is required. Currently, the efficiency of commercial equipment is expressed by either an Energy Efficiency Ratio (EER) or SEER. These ratings are obtained under standard Air-Conditioning and Refrigeration Institute (ARI) test conditions. Forward modeling packages could be improved by mapping the performance of the DX systems over a more broad range of conditions to better estimate field performance on an annual basis.

Given these challenges in measuring and predicting energy efficiency, significant effort has been given to accurately model the performance of the UTSS over a range of conditions and confirm the accuracy of the model with relevant field data. Even with this effort, assumptions must still be made about the differences in operating characteristics between UTSS and DX systems. Further, obtaining data to support these assumptions in the field is challenging due to the

limitations of field measurements. The solution is to accurately characterize both UTSS and DX systems over a range of static lab conditions. Without this comparison, modeling the impact that UTSS has on DX systems will be limited to standard ARI conditions, which will not capture the effects of day/night temperature swings, cycling, and the other factors already mentioned. In lieu of having such data for standard DX systems, empirical data-driven modeling must be used to characterize the DX equipment on site, over actual site specific conditions and variations. Also, the performance of UTSS systems must be evaluated on a 24 hour basis due to operating characteristics. A test strategy of alternating days or weeks between systems must be avoided for comparing the performance of UTSS vs. DX, because field conditions are virtually impossible to hold adequately constant.

## PERFORMANCE TEST METHODOLOGIES

There are three methods that can be used to compare the performance of a DX system without a UTSS, to one with a UTSS.

**Lab Testing** can be conducted on UTSS/DX hybrid systems, running either configuration at separate times, under identical static conditions. This approach is limited, however, in that it cannot practically be used to evaluate a broad range of applications, weather conditions, configurations, or operating strategies, due to its intense capital, time and other resource requirements. Results from this method are not the primary point of this paper, although they do make a contribution.

For **Field Testing**, an empirical model of one system can be compared to the actual results of the other, as if they were running simultaneously, under absolutely identical conditions. In the case of this paper, the performance of the actual UTSS/DX hybrid system is compared to “what would have happened” with the unmodified DX system by virtue of an empirical DX model, created from field data. The empirical evaluations of the DX system must be conducted over an adequate period of time to account for an appropriate range of field conditions, and proper characterization. But when done properly, this method can be used to validate predicted performance.

Predicted **Performance Testing** is generated by model-based simulation of both systems. The advantage of this modeling approach is that it is by far the least expensive to execute, and it can be quickly applied to the broadest array of conditions and applications. In this case, the DX system model comes from industry standards and commercial software modeling systems. The UTSS model is managed similarly, but at the time of this paper, there is no approved ARI or ASHRAE standard to follow. In lieu of such a standard, a special methodology has been devised for characterizing UTSS systems, and executed by an independent 3<sup>rd</sup> party to provide the necessary data for modeling and predicting performance (Intertek 2008). Accurate results from this method require both the DX and UTSS models to be validated as described in Chapter 32—

Energy Estimating and Modeling Methods of the 2005 ASHRAE Handbook. The UTSS model presented in this paper is so validated, and the DX model is assumed to be valid as per industry practice.

Field Testing and Performance Testing both impose the notion of a UTSS “cycle.” For purposes of fair comparisons to a DX system working alone, the energy savings created through the on-peak use of the UTSS must be compared to the total energy consumption used to restore, manage, and deliver that UTSS capacity. A single cycle, then, starts at the beginning of the scheduled UTSS cooling period (whether cooling actually is called for at that time or not), and that cycle concludes 24 h later, thereby capturing the energy to manage and restore storage capacity used during cooling.

## Proposed Method of Collecting Certified Performance Data

The UTSS model discussed in this paper was fully tested in lab conditions over a range of outdoor ambient temperatures during the charge cycle. Mapping the performance over a range of conditions is necessary for accurate characterization and modeling. Because the UTSS cooling capacity is not impacted by outdoor ambient temperatures, the system cooling performance was verified by applying a 5 ton (17.6 kW) load and measuring the delivered cooling to confirm the net usable storage. The average saturated condensing temperature of the refrigerant over the discharge duration was also calculated from refrigerant pressure measurements taken in the evaporator return line at the inlet to the UTSS. The saturated condensing temperature indicates the temperature of the refrigerant being supplied to the evaporator.

UTSS performance should be mapped over a range of outdoor ambient conditions. This requires the use of a suitable outdoor test room. Construction and performance details of the room should follow the requirements set forth in ASHRAE Standard 37, Methods of Testing for Rating Electrically Driven Unitary Air-Conditioning and Heat Pump Equipment. The system should complete five full charge and discharge cycles at 55, 65, 75, 85, and 95°F (12.8, 18.3, 23.9, 29.4, and 35.0°C) outdoor ambient conditions. During the charge cycles, recorded data should include charge duration and the total power input to the system. The system should be discharged with a specified load and the net usable storage and average saturated condensing temperature recorded. These tests should follow industry test standards and be conducted or witnessed by an accredited or industry-accepted 3<sup>rd</sup> party test entity. Currently, the scope of existing test standards, such as ARI Standard 900—Performance Rating of Thermal Storage Equipment Used for Cooling, do not cover UTSS equipment. Specifically, ARI Standard 900 is currently being revised to include such systems and outline test methods for determining performance. The test method described above closely follows the proposed appendices to the ARI Standard 900.

## Sample Test Results

Following the proposed test method outline above, the certified performance data in Table 1 were obtained for the UTSS described in this paper.

The more detailed data collected during these charge cycle tests were utilized further to develop bi-quadratic parameters, used to describe the system performance based on ambient temperature and the percent of charge complete. This technique was originally proposed by the California Energy Commission (CEC), and was implemented under their guidance by a third party, in DOE 2.1e. Ultimately, these functions describe the charging capacity and system EER over the range of ambient conditions tested, enabling accurate predictions of energy consumption in the model. Details of this modeling technique and implementation in DOE 2.1e can be found on the CEC's web site (CEC 2006).

## PREDICTIVE MODELING PROCESS

Weather data and building simulation packages are combined with certified performance data to analyze energy savings over an entire year. This allows simulation of a DX system utilizing TES and comparison to the same system without storage (see Figure 2).

## Method of Predicting Energy Savings

The model described in the following sections used weather data generated by the DOE's building simulation package, Energy Plus. Energy Plus was also used to generate the load profile and average load shape on an annual basis. The CEC model for predicting the performance of DX and UTSS systems was utilized. Rather than use a commercial energy modeling software package, an in-house model was created to facilitate other analyses unrelated to this paper. Combining load profile, outdoor conditions, and certified performance data allows the generation of demand and energy 8760-h profiles for both UTSS and DX systems. Total energy consumption of the DX system, including predicted on-peak energy, can be compared to the total energy predicted for the TES-based system to determine peak shift, cooling performance, and ultimately energy efficiency. A limitation of this

approach is the accuracy of the DX modeling equations over a practical range of operating conditions.

## FIELD DATA ANALYSIS

Field data was analyzed for a UTSS installation in a hot, dry western climate. The pre-existing packaged rooftop equipment is a 5-ton, High Efficiency 11.1 EER, R-22 refrigerant unit with gas heating; commissioned in late 2007. It is a typical rooftop mounted unit that is subjected to solar thermal heat gain most hours of the day. Interconnection is an R-410A insulated liquid supply and return line connected to a liquid overfeed (flooded) refrigerant coil (no expansion device required) inserted into the unit (see Figures 3 and 4).

Monitoring equipment includes current sensors on the UTSS and DX systems, which are calibrated for true power and power factor. Also, there were temperature sensors placed in the supply and return ducts, and one for outdoor ambient temperature (see Figure 5). All sensors are measured every second, but averaged and stored over every 5 minute period.

An empirical model of the DX system at the site was created over the course of a 31 consecutive-day test period, and this model was used to predict the performance of a DX system running in the same conditions as actually witnessed using the UTSS/DX hybrid.

Some assumptions were necessary in the analysis due to limitations of field measurements such as airflow and humidity. The airflow was assumed to be constant and the latent load was neglected. The relative served load was determined by dry bulb temperatures measured at the inlet and outlet of the evaporator coil. Since the UTSS system's dehumidification capability is equal or greater to that of the DX system<sup>1</sup>, the use of relative load served makes the predicted energy savings in favor of the UTSS system conservative. A confirmation of equivalent performance can also be seen by the data presented in Figure 6 which shows return air temperature (indicative of space conditions) versus outdoor ambient temperature during operation of each system independently providing cooling.

<sup>1</sup>As determined through Lab Testing, not described in detail in this paper due to non-disclosure agreement restrictions.

**Table 1. Sample Performance Test Results**

Outdoor Condition, °F (°C)	Charge		Discharge		
	Charge Duration, h	Average Demand, kW	Applied Load, ton (kW)	Usable Storage, ton-h (kWh)	Ave. Condensing Temp., °F (°C)
55 (12.8)	9.24	2.81	5 (17.6)	31.53 (110.9)	41.6 (5.3)
65 (18.3)	9.84	3.12	5 (17.6)	31.74 (111.6)	41.7 (5.4)
75 (23.9)	10.36	3.47	5 (17.6)	31.45 (110.6)	41.7 (5.4)
85 (29.4)	11.17	3.86	5 (17.6)	31.59 (111.1)	41.8 (5.4)
95 (35.0)	12.25	4.28	5 (17.6)	31.54 (110.9)	41.9 (5.5)

Both systems are shown to maintain comparable return air temperatures across a broad range of temperatures.

### Comparison to Predicted Results

Results for both the field test and predictive test are shown in Table 2.

Notes:

- Melt Duration shows the amount of time the UTSS provided cooling on a given day.
- Peak Coverage shows the percent of the scheduled on-peak service time that was served by the UTSS. A value less than 100% means that the UTSS ran out of ice early.
- Max Ambient is the highest ambient temperature reached during the scheduled peak.
- Energy shift is the energy that the existing EER 11.1 system would have consumed to serve each day's peak cooling load (as determined empirically), minus the amount that was actually consumed by the UTSS to provide that same cooling.
- Energy Req'd is the total energy consumed by the UTSS during all other (non-cooling) times of the day. This includes the energy to restore the ice tank's capacity, plus all parasitic losses.
- Ave Ice Make Temp is the average temperature over the course of the actual ice make process for a given cycle.
- All values are corrected for true power.

As defined above, energy neutrality is achieved if the Energy Required is equal to (or less than) the Energy Shifted.

As shown in Table 2, the 11.1 EER DX system experienced a 1.83% energy savings with the addition of a UTSS system.

It is valuable to also note that in-situ, the UTSS provided cooling (melted) much longer than in the predicted model – over two hours more. This is strongly indicative of an oversized DX system. The UTSS liquid overfeed technology allows the UTSS evaporator coil to match the actual load precisely. If less than 5 tons (17.6 kW) of load is present, the net impact is that the unit will simply supply its capacity over a longer time period. On the other hand, typical DX performance for an oversized unit will address the same situation by cycling its compressor. This translates into extra energy consumption, which serves to explain some of the efficiency gains, vs. the 2.8% predicted loss.

This finding also suggests that DX modeling for the purposes of comparative analysis with UTSS may need some adjustment. Figure 7 shows the actual DX demand during the test, vs. the CEC equations for the DX system using the model's ARI specifications and default performance correction coefficients. It is conjecture that errors in the DX model stem from partial load factor, field conditions vs. lab conditions, maintenance condition, and favorable modeling assumptions.

The data shows that the model underestimates the demand of the DX system. Consequently, using this model for comparison further accentuates the conservative nature of the “energy neutral or better” model prediction. Overall, this field test serves as confirmation of the predictive test's usefulness for estimating UTSS performance.

## Modeling Overview

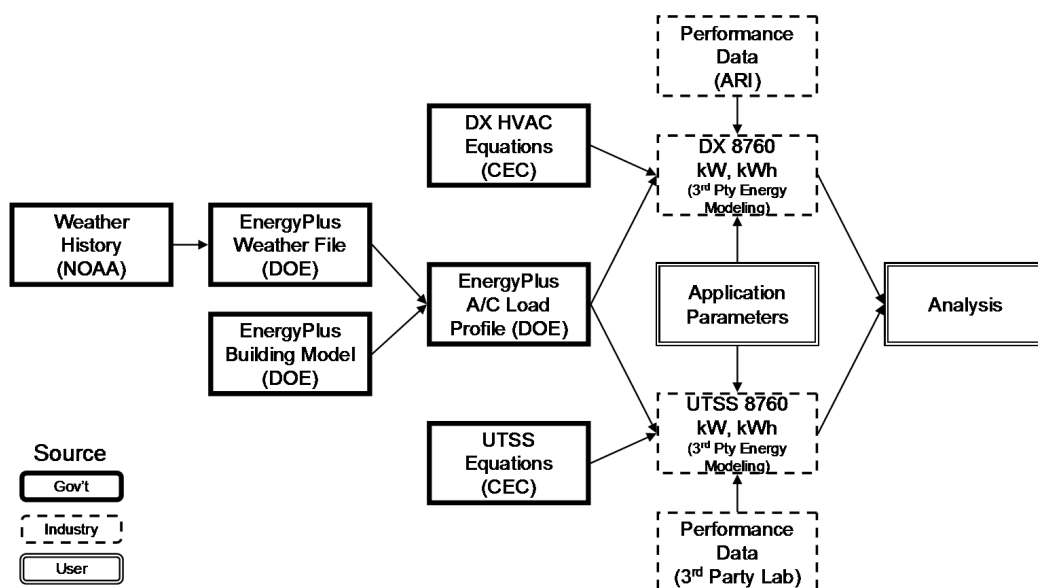
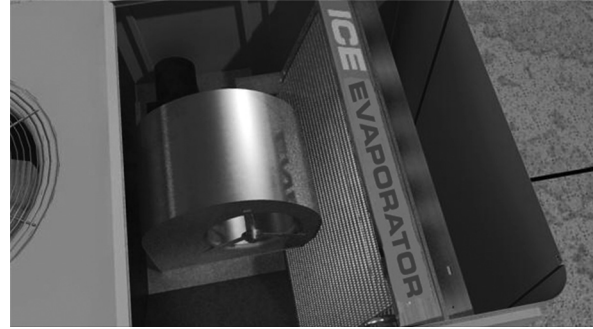

Figure 2 Modeling overview.



**Figure 3** UTSS (right) connected to standard rooftop unit (left). Installation photo.



**Figure 4** Typical view of a pumped liquid overfeed coil inserted into a packaged DX system.

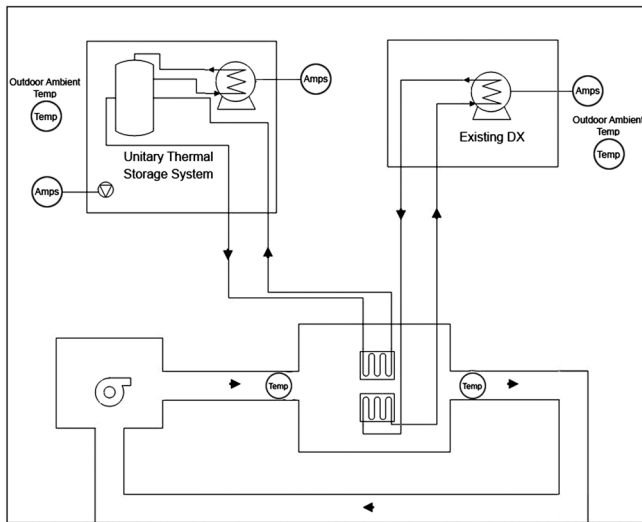

**Figure 5** Location and sensors types for field measurements.

## BENEFITS IN DIFFERENT CLIMATE ZONES

The field data presented from the test site shows the potential impact of UTSS for DX systems in a hot, dry climate. The model was then used to predict the potential benefits in two other climates including one in a more moderate climate and another in the southeast (hot, humid). Table 3 summarizes the results of these simulations.

## CONCLUSIONS

While the UTSS energy storage conversion process does have unavoidable heat transfer conversion losses, this is more than offset by the gains achieved from the factors listed above, with the day/night temperature offset being the most significant factor. The predictive model routinely estimates that the energy impact of adding a UTSS to a DX system is neutral or

better. While the site efficiencies delivered by the UTSS system are well proven in the field, they vary in magnitude based on DX system equipment type, DX system age, usage patterns, and ambient conditions. Therefore, quantification of “true” performance requires careful laboratory testing under tightly controlled conditions.

To that end, the performance of the UTSS technology has been fully demonstrated through third party verification tests (Intertek 2008). The explicit purpose of these tests are not to determine energy efficiency per se, but to characterize the system’s performance at a variety of temperatures, under controlled conditions. This data is then used in conjunction with detailed weather and building load models to simulate yearly (8760 hours) energy consumption comparisons to DX systems, to substantiate energy efficiency claims, among other purposes.

While these commercial modeling environments do include the UTSS heat transfer conversion losses and ETL performance characterization data, they do not include accommodation for any of the energy efficiency factors described above other than the day/night temperature profile. As a result, the true energy performance of the UTSS system is understated. Furthermore, as the above field results illustrate, the method of modeling DX systems also understates the energy efficiency benefits in the models. A more robust model for DX systems operating outside of standard ARI conditions is recommended.

Two commercial modeling environments capable of modeling UTSS systems now exist. Both systems use the data from certified third party tests as a basis for all calculations. UTSS model files used in these energy modeling packages have been fully vetted and approved by the CEC for use with Title24 Compliance (CEC 2008) and the UTSS units themselves are listed as building cooling energy efficiency measures that exceed the Time-Dependent Valuation (TDV) performance of 16 SEER DX units. These modeling tools are also used to model more traditional chiller-based TES systems.



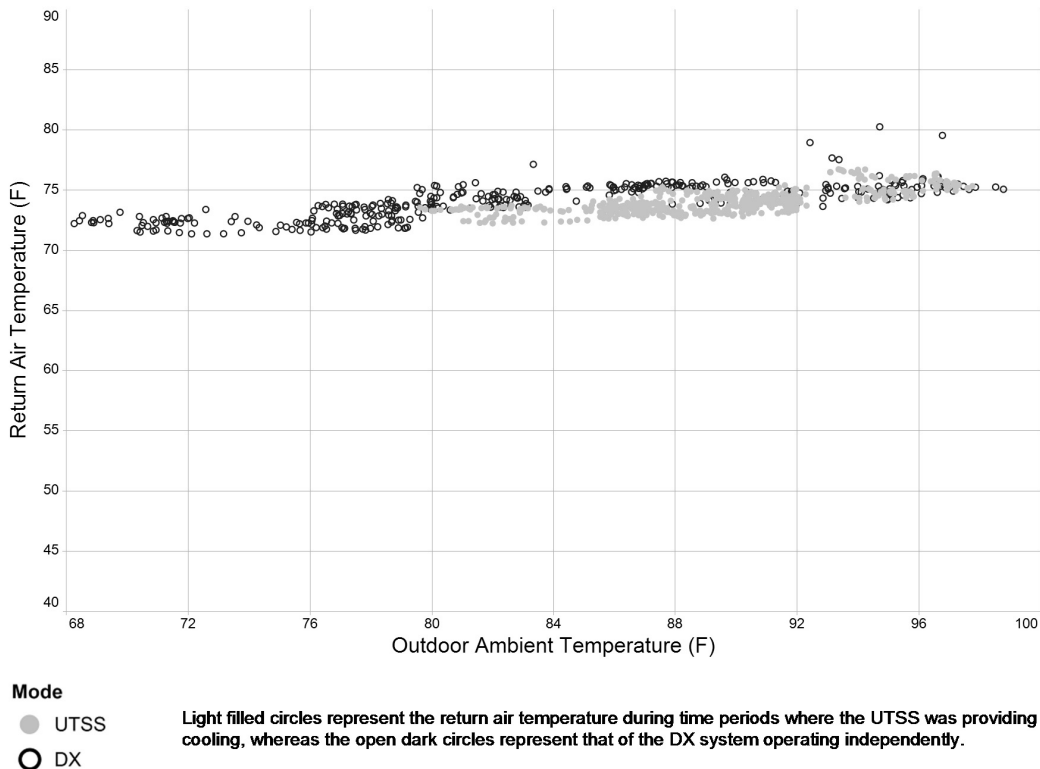

**Figure 6** Return air temperatures during UTSS and DX cooling.

**Table 2. Field and Predictive Test Results**

Situation	Average Melt Duration, h	Minimum Peak Coverage	Average Max. Ambient, °F (°C)	Average Energy Shift, kWh	Average Energy Req'd, kWh	Ave Ice Make Temp., °F (°C)
Actual: 5-Ton, 11.1 EER DX, Test Site	7:57	100%	91.4 (33.0)	32.8	32.2	69.5 (20.8)
Model: comparable to above Test Site	5:43	100%	90.7 (32.6)	28.2	29.0	67.1 (19.5)

Even so, these models show break-even site energy efficiency performance, based on nighttime versus daytime temperature differentials alone. Adding in the benefits of the other factors completes the picture: the elimination of cycling adds 5 to 9% efficiency improvement to the DX system on-peak; eliminating the need to oversize improves year-round efficiency by 5 to 25%; elevated rooftop and humidity factors add another 5% in favor of the UTSS. In creating a hybrid UTSS/DX system, the net impact to overall efficiency is “energy neutral or better.”

**REFERENCES**

ASHRAE. 2005. *2005 ASHRAE Handbook—Fundamentals*. Chapter 8, Thermal comfort. Atlanta: American Society of Heating, Refrigerating and Air-Conditioning Engineers, Inc.

ASHRAE. 2005. *2005 ASHRAE Handbook—Fundamentals*. Chapter 14, Measurement and instruments. Atlanta: American Society of Heating, Refrigerating and Air-Conditioning Engineers, Inc.

ASHRAE. 2005. *2005 ASHRAE Handbook—Fundamentals*. Chapter 28, Climatic design information. Atlanta: American Society of Heating, Refrigerating and Air-Conditioning Engineers, Inc.

CEC. 2006. Title 24 2005 Standards. <http://www.energy.ca.gov/2006publications/CEC-400-2006-006/CEC-400-2006-006-SF.PDF>.

CEC. 2008. Approved ice storage air conditioners. [http://www.energy.ca.gov/title24/2005standards/special\\_case\\_appliance/compliance\\_options/2008-06-20\\_APPROVED\\_ICE\\_STORAGE\\_AIR\\_CONDITIONERS.PDF](http://www.energy.ca.gov/title24/2005standards/special_case_appliance/compliance_options/2008-06-20_APPROVED_ICE_STORAGE_AIR_CONDITIONERS.PDF)

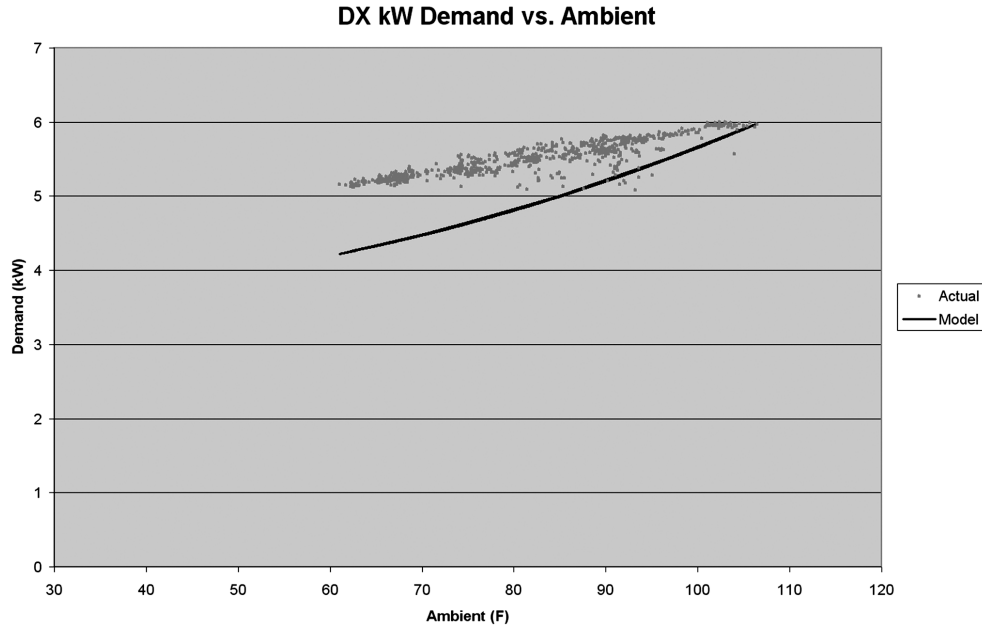

Figure 7 DX kW demand, measured, and predictive values.

Table 3. Predictive Results in Alternative Climate Zones

Situation	Average Melt Duration, h	Minimum Peak Coverage	Average Max Ambient, °F (°C)	Average Energy Shift, kWh	Average Energy Req'd, kWh	Ave Ice Make Temp, °F (°C)
Model: Retail 20T, Riverside, CA	6:00	100%	86.3 (30.2)	27.0	27.0	62.1 (16.7)
Model: Outpatient clinic, 15T, Atlanta, GA	5:54	100%	95.7 (35.4)	35.1	35.6	77.3 (25.2)

Domanski, P. and W.V. Payne. 2002. Properties and cycle performance of refrigerant blends operating near and above the refrigerant critical point. National Institute of Standards and Technology, ARTI 21-CR Project. Gaithersburg, MD.

Faramarzi, R. 2004. Performance evaluation of typical five-ton roof top air conditioning units under high ambient temperatures. Southern California Edison, 2004 FMI Conference, Dallas, TX.

Henderson, H., Jr., D. Parker, and Y.J. Huang. 2000. Improving DOE-2's RESYS routine: User defined functions to provide more accurate part load energy use and humidity predictions. CDH Energy/Florida Solar Energy Center/Lawrence Berkeley Laboratory.

Intertek. 2008. Report on performance of ice energy's ice bear. <http://www.ice-energy.com/portals/0/ETL%20Report.pdf>

Khattar, M.K., M.V. Swami, and N. Ramanan. 1987. Another aspect of duty cycling: Effects on indoor humidity, FSEC-PF-118-87, ASHRAE, 1987. Atlanta: American Society of Heating, Refrigerating and Air-Conditioning Engineers, Inc.

Proctor, J., Z. Katsnelson, and B. Wilson. 1995. Bigger is not better: Sizing air conditioners properly. *Home Energy*, May/June 1995.

Proctor, J. and J. Wilson. 1998. Negative technical degradation factors supplement to persistence studies. California DSM Advisory Committee Persistence Subcommittee, 1998.

Wells, W., D. Bivens, A. Yokozeki, and C.K. Rice. 1999. Air conditioning system performance with R410A at high ambient temperatures. ASHRAE Annual Meeting, Seattle, WA.